

North America - February 2025



You spot it from afar

# LEUCOS

# Over sixty years of lighting history

**LEUCOS was born in 1962 near Venice, where craftsmanship is synonymous with art.**

Since the beginning, we have been known for creating lamps of unmistakable quality and unparalleled beauty. The handblown glass represents the local tradition, but behind every new project there is a broader ambition.

With a deep passion for timeless beauty, we are continuously driven to innovate and elevate our modern classics. Our formula is a combination of design, materials, manufacturing techniques, technologies, and exceptional human resources.



We offer both standard products with a high degree of customization options and fully bespoke solutions. Our mission is to cultivate value for our clients, partners, and company.

This drives us to produce beautiful, expertly crafted, dependable, efficient, and long-lasting products through innovation and simplification.

Our commitment to excellence shines in every product we create.

**You spot it from afar.**

## AELLA collection

Conceived in 1968 by the creative minds of designers Renato Toso and Noti Massari, the Aella Collection represents the essence of Leucos' timeless design.

Aella is the "tornado" embodied by the soft curves of the handblown glass diffuser, swirling to capture a harmonious and evanescent cyclone of light. The light emits as a gentle flame, evenly spreading throughout the room.

With three sizes available for both table and suspension versions, as well as multiple combinations of colors for the structure and diffuser, Aella caters to diverse needs, allowing you to tailor the ambiance to your preference. The user-friendly, easily replaceable LED light sources ensure longevity and easy maintenance, thanks to a smart disassembly system, making Aella a perfect fit for any space.

Now expanded beyond table and suspension versions, the collection includes the AELLA TR floor lamp, featuring a longer matte black extruded aluminum body that provides a majestic presence and stability while maintaining the iconic design's lightness.

After more than 50 years, LEUCOS unveils a special edition of its iconic Aella collection by Toso & Massari. The Aella T 45 "Openworked" is a tabletop lamp inspired by Swiss watches, showcasing its intricate mechanics rather than concealing them.



**AELLA T 30**

Diffuser: Transparent With White Spot  
Structure: Matte White

# AELLA T

T 30, T 45, T 54

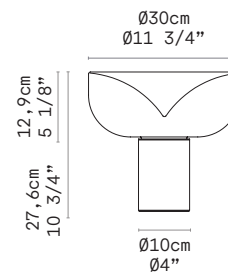

**AELLA T 30**

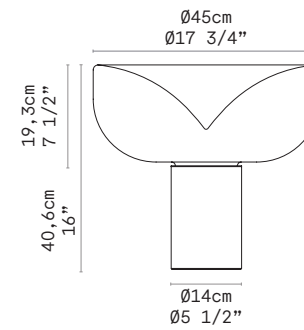

**AELLA T 45**

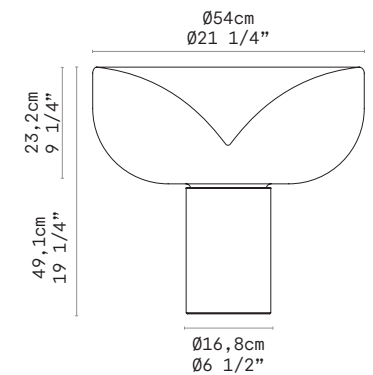

**AELLA T 54**

**Designer**

Toso & Massari

**Category**

Indoor

**Marks**

DRY LOCATION

**Typology**

Table

**Light source data**

LED 3000K  
LED 2700K

**Dimming Protocol**

Dimmer on cord

**Materials**

Handblown glass / Metal

**AELLA S 30**

Diffuser: Shaded Burgundy  
Structure: Matte Black



# AELLA S

S 30, S 45, S 54

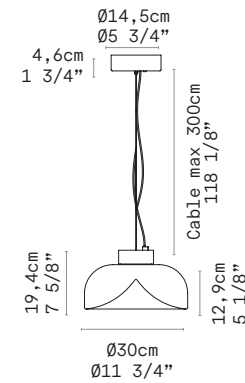
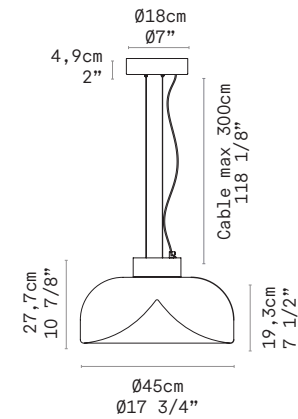
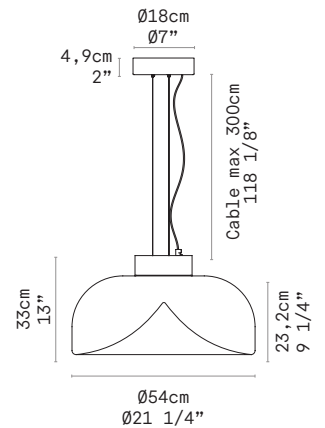
**AELLA S 30****AELLA S 45****AELLA S 54****Designer**

Toso & Massari

**Category**

Indoor

**Marks**

DRY LOCATION

**Typology**

Pendant

**Light source data**

LED 3000K  
LED 2700K

**Dimming Protocol**

Push-dim; 0/1-10V; Dali

**Materials**

Handblown glass / Metal



**AELLA S 30 L**  
 Diffuser: Alabaster With  
 Brush Strikes  
 Structure: Matte Black

# AELLA S L

S 30 L , S 45 L, S 54 L



**AELLA S 30 L**

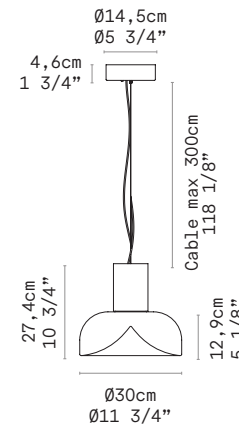

**AELLA S 45 L**

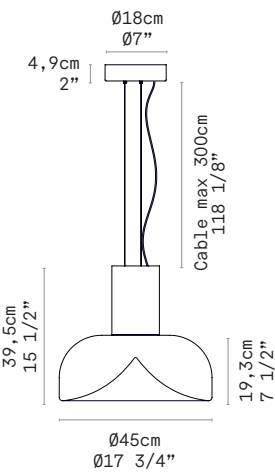

**AELLA S 54 L**

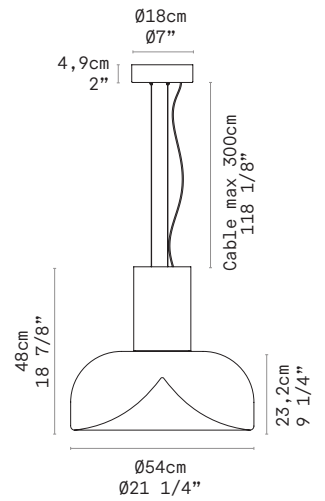

**Designer**  
 Toso & Massari

**Category**  
 Indoor

**Marks**  
 DRY LOCATION 

**Typology**  
 Pendant

**Light source data**  
 LED 3000K  
 LED 2700K

**Dimming Protocol**  
 Push-dim; 0/1-10V; Dali

**Materials**  
 Handblown glass / Metal

# AELLA

T 30, T 45, T 54  
S 30, S 45, S 54  
S 30 L, S 45 L, S 54 L

## Glass Diffuser

## Glass Diffuser

IN STOCK

ON REQUEST

Transparent  
With White Spot

Shaded Burgundy

Smoke Grey

Transparent "Pulegoso"  
With Metal Powder

Shaded White

White Shaded Pink

Alabaster  
With Brush Strikes

Matte  
Black



Metal Structure

Matte  
Bronze



Matte  
White





**AELLA TR 45**  
Diffuser: Shaded Burgundy  
Structure: Matte Black



**AELLA TR 45**

Diffuser: Transparent "Pulegoso"  
With Metal Powder Inclusion  
Structure: Matte Black

# AELLA TR

TR 45

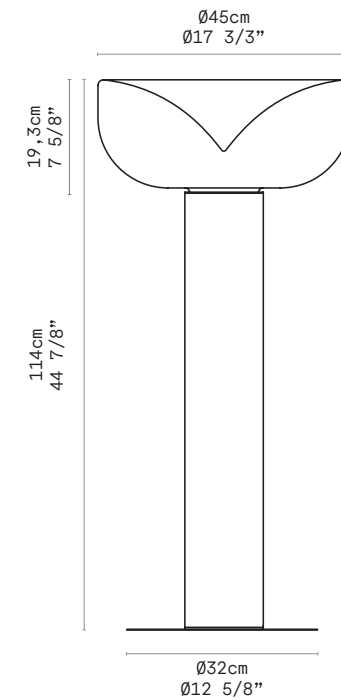
**AELLA TR 45****Designer**

Toso &amp; Massari

**Typology**

Floor

**Dimming Protocol**

Dimmer on cord

**Category**

Indoor

**Light source data**

LED 3000K  
LED 2700K

**Materials**

Handblown glass / Metal

**Marks**

DRY LOCATION

# AELLA TR

TR 45

## Glass Diffuser

## Glass Diffuser

IN STOCK

ON REQUEST

Transparent  
With White Spot

Shaded Burgundy

Smoke Grey

Transparent "Pulegoso"  
With Metal Powder Inclusion

Shaded White

White Shaded Pink

Alabaster  
With Brush Strikes



Metal Structure

Matte  
Black

## AELLA T Openworked

The Aella T 45 Openworked special edition balances timeless elegance with a bold, transparent design that redefines the original 1968 model. Featuring a hand-blown glass diffuser with a unique white spot, each lamp is individually crafted, ensuring no two are identical. The transparent base reveals natural copper stems that oxidize over time, adding character to the piece.

The LED light (2700K or 3000K) is powered through these stems. A brushed stainless steel plate beneath the base highlights the lamp's name, production year, and the designers' signatures. Exclusive packaging further enhances the special edition experience.

AELLA T 45  
OPENWORKED





AELLA T 45  
OPENWORKED

# AELLA T Openworked

T 45 Openworked

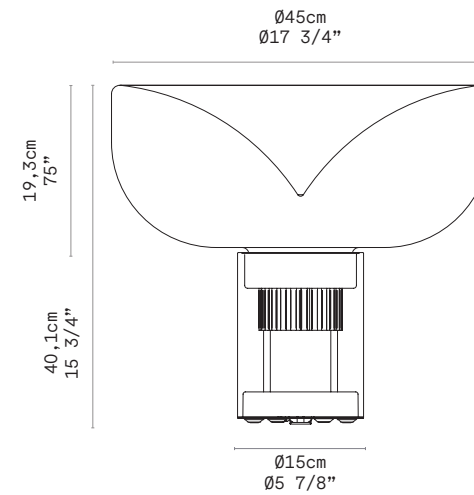

AELLA T 45 Openworked

## Designer

Toso & Massari

## Category

Indoor

## Marks

DRY LOCATION

## Typology

Table

## Light source data

LED 3000K  
LED 2700K

## Dimming Protocol

Dimmer on cord

## Materials

Blown Glass/ Metal +  
Anodized Aluminum and  
Natural Copper Rods  
Base: Borosilicate Glass

## STACKING collection

Designed by Rockwell Group, the Stacking Collection merges cutting-edge technology with traditional glassmaking techniques. It includes three sets of floor lamps and horizontal and vertical pendant lights.

The floor version, conceived in 2007, pays homage to the Venetian glassmaking tradition through the “incamiciato” technique, layering multiple glasses to create unique colors and opacities. When the cylindrical modules overlap, they cast a sophisticated ambient light.

Sixteen years later, the collection expanded with suspended lamps, featuring cylindrical diffusers powered by 5 high-quality LED strips and decorative blown borosilicate glass. Available in three sizes for vertical pendants and two for horizontal ones, the suspended range can be arranged in clusters to create beautiful and captivating lighting compositions.

Stacking S is now available in new finishes: Satin Black, Metallic Titanium, and Metallic Petrol Blue, with machined aluminum end-caps in matte black or anodized aluminum, which secure the structure and serve as suspension anchoring points.

In 2024, the Stacking S H RIG debuts, showcasing ribbed borosilicate glass for enhanced lighting effects. Available in the new Tabacco and Transparent finish, this version offers an elegant addition to the collection.

The “Naked” version without decorative glass is also available.



STACKING S 90 V  
Diffuser: Satin Black  
Structure: Anodized Aluminum



**STACKING S 180 H**

Diffuser: Transparent  
Structure: Anodized Aluminum

# STACKING S H

S 120 H, S 180 H

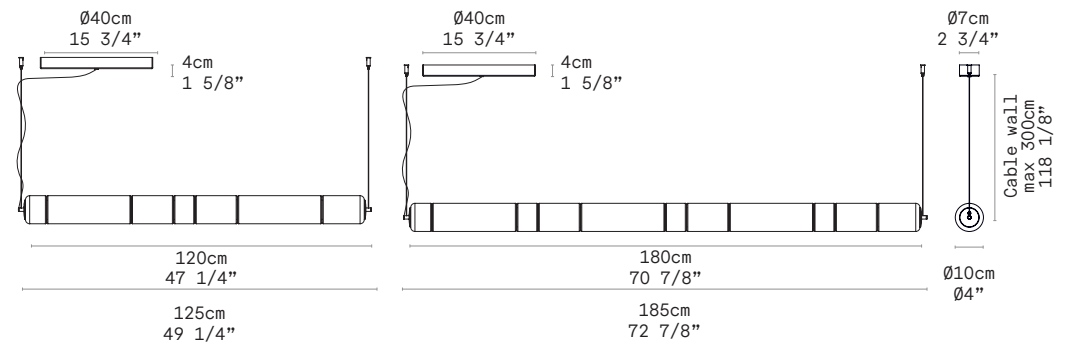

**STACKING S 120 H**

**STACKING S 180 H**

**Designer**

David Rockwell

**Typology**

Pendant

**Dimming Protocol**

0/1-10V; Phase cut

**Category**

Indoor

**Light source data**

LED STRIP 3000K  
LED STRIP 2700K

**Materials**

Blown borosilicate glass /  
Aluminum

**Marks**

DRY LOCATION 

**STACKING S 90 V**

Diffuser: Metallic Petrol Blue  
 Structure: Matte Black Aluminum



# STACKING S V

S 30 V, S 60 V, S 90 V



**STACKING S 30 V**

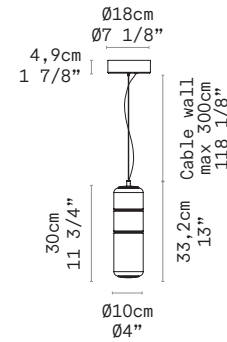

**STACKING S 60 V**

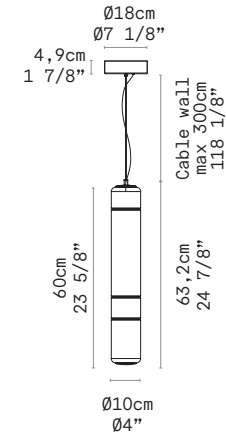

**STACKING S 90 V**

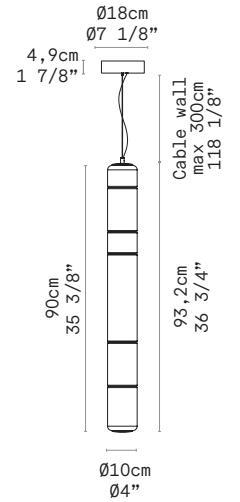

**Designer**

David Rockwell

**Category**

Indoor

**Marks**

DRY LOCATION 

**Typology**

Pendant

**Light source data**

LED STRIP 3000K  
 LED STRIP 2700K

**Dimming Protocol**

0/1-10V; Phase cut

**Materials**

Blown borosilicate glass /  
 Aluminum

# STACKING

S 120 H, S 180 H

S 30 V, S 60 V, S 90 V

## Glass Diffuser

## Glass Diffuser

IN STOCK

ON REQUEST

Transparent

Satin Black

Metallic Petrol Blue

Metallic Titanium

Anodized  
Aluminum

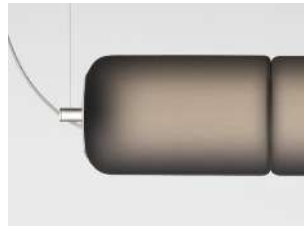

Matte  
Black  
Aluminum

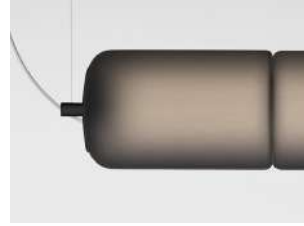

Metal Structure



**STACKING RIG S 180 H**

Diffuser: Transparent Rigadin

Structure: Anodized Aluminum





**STACKING RIG S 180 H**  
 Diffuser: Transparent Rigadin  
 Structure: Anodized Aluminum

# STACKING RIG S H

RIG S 120 H, RIG S 180 H

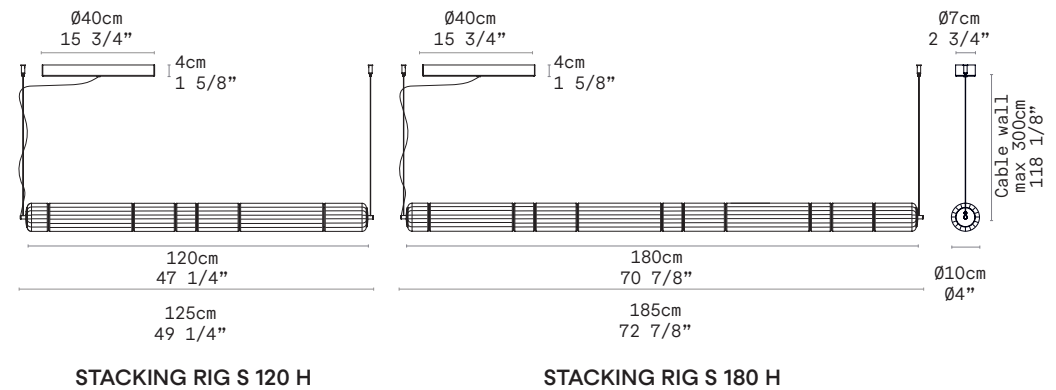

<b>Designer</b>	<b>Tipology</b>	<b>Dimming Protocol</b>
David Rockwell	Pendant	0/1-10V; Phase cut
<b>Category</b>	<b>Light source data</b>	<b>Materials</b>
Indoor	LED STRIP 3000K LED STRIP 2700K	Blown Borosilicate Glass / Aluminum
<b>Marks</b>		

DRY LOCATION 

**STACKING RIG S 60 V**

Diffuser: Tobacco Rigadin

Structure: Anodized Aluminum





**STACKING RIG S 60 V**

Diffuser: Tobacco Rigadin  
Structure: Anodized Aluminum

# STACKING RIG S V

RIG S 30 V, RIG S 60 V, RIG S 90 V



**STACKING RIG S 30 V**

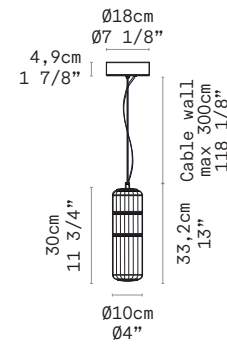

**STACKING RIG S 60 V**

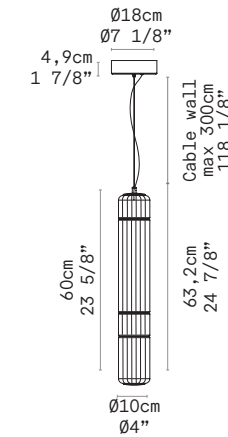

**STACKING RIG S 90 V**

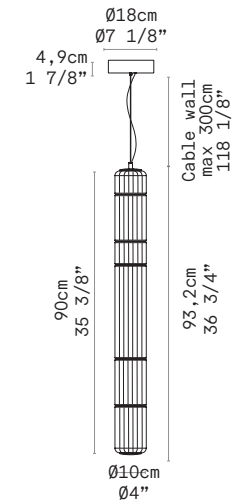

**Designer**

David Rockwell

**Category**

Indoor

**Marks**

DRY LOCATION 

**Typology**

Pendant

**Light source data**

LED STRIP 3000K  
LED STRIP 2700K

**Dimming Protocol**

0/1-10V; Phase cut

**Materials**

Blown borosilicate glass /  
Aluminum

# STACKING RIG

RIG S 120 H, RIG S 180 H  
RIG S 30 V, RIG S 60 V, RIG S 90 V

Glass Diffuser

Glass Diffuser

Transparent Rigadin

Tobacco Rigadin

Anodized  
Aluminum



Metal Structure

Matte  
Black  
Aluminum



**STACKING TR B**

Diffuser: Smoke Grey, White, Smoke  
Grey, White, Mirror  
Structure: Chrome





**STACKING TR**  
From the left: C, D and B

# STACKING TR

B, C, D

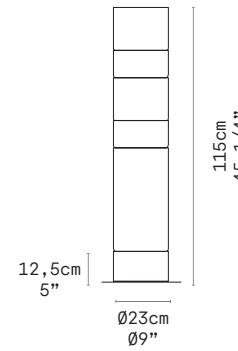

**STACKING TR B**

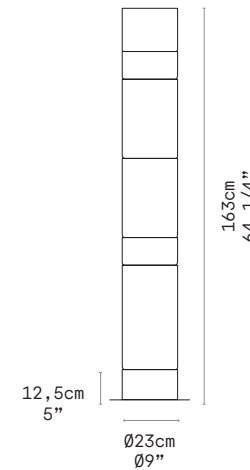

**STACKING TR C**

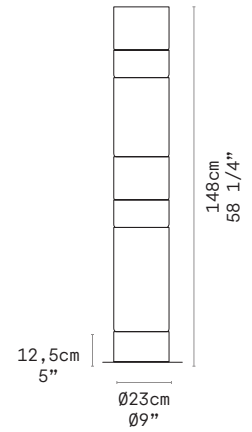

**STACKING TR D**

**Designer**  
Rockwell Group

**Category**

Indoor

**Marks**  
DRY LOCATION

**Typology**

Floor

**Light source data**

GU10

**Dimming Protocol**

On-Off switch on cord

**Materials**

Handblown glass / Metal

## AURELIA collection

Designed by the visionary Patrick Jouin, Aurelia is a breathtaking collection of suspension lamps in which functionality and craftsmanship meet aesthetics and elegance.

Aurelia is equipped with a downwards direct light source and an upwards indirect light ring. The metal structure contains and hides from sight all electronic and heat-dissipation elements. The LED light sources are user-friendly and easily replaceable, ensuring longevity and easy maintenance thanks to a smart disassembly system.

Available in two shapes and two sizes, Aurelia Collection offers several color combinations for the handblown glass diffuser and the metal structure.



### AURELIA BOLD S 22

Diffuser: Transparent Pulegoso  
with Metal Powder Inclusion  
Structure: Vintage brass





**AURELIA S 45 SS**

Diffuser: Transparent Pulegoso  
with Metal Powder Inclusion  
Structure: Matte gunmetal

**AURELIA BOLD S 22 SS**

Diffuser: Transparent "Pulegoso"  
With Metal Powder Inclusion  
Structure: Vintage Brass

# AURELIA SS

S 45 SS, BOLD S 22 SS



**AURELIA S 45 SS**

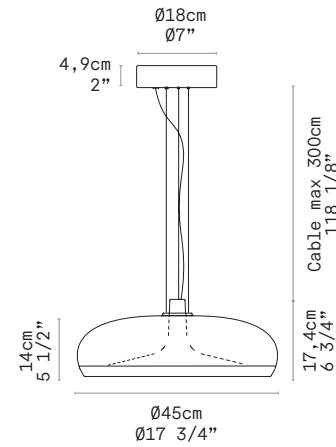

**AURELIA BOLD S 22 SS**

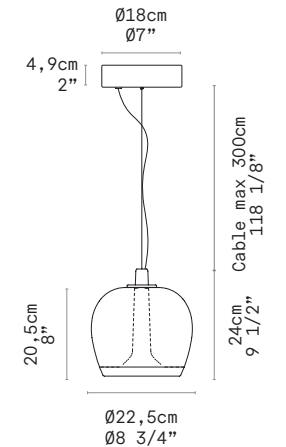

**Designer**

Patrick Jouin

**Typology**

Pendant

**Dimming Protocol**

Push-dim; 0/1-10V; Dali

**Category**

Indoor

**Light source data**

Direct & indirect LED 3000K  
Direct & indirect LED 2700K

**Materials**

Handblown glass / Metal

**Marks**

DRY LOCATION 

# AURELIA SS

S 45 SS, BOLD S 22 SS

## Glass Diffuser

## Glass Diffuser

Smoke Grey

Shaded Burgundy

Transparent "Pulegoso"  
With Metal Powder Inclusion

Transparent Water Effect

Blue Water Effect

Matte  
Gunmetal



Vintage  
Brass



Matte  
White



Metal Structure

## LIGHTBODY collection

Lightbody is a piece by Jörg Hugo, a designer exploring the relationship between materiality, form, and space.

Available in floor/table and suspended versions, Lightbody's glass diffuser is completely hand made using the "free blown" glass technique. This artisanal method requires a glassmaker maestro to shape the glass without the constraints of molds, giving life to a unique and unrepeatable lamp every time.

Shielded by the glass, the light comes out with a warm, atmospheric quality. The bright bulb accentuates the unique contours of the glass with lively highlights.

Available in several color combinations both for floor/table and suspended versions, Lightbody brings a handcrafted elegance to your lighting choices.



LIGHTBODY T  
Diffuser: Shaded Burgundy



**LIGHTBODY S**  
Diffuser: Transparent Pink

**LIGHTBODY T**  
Diffuser: Transparent Pink

# LIGHTBODY

S, T

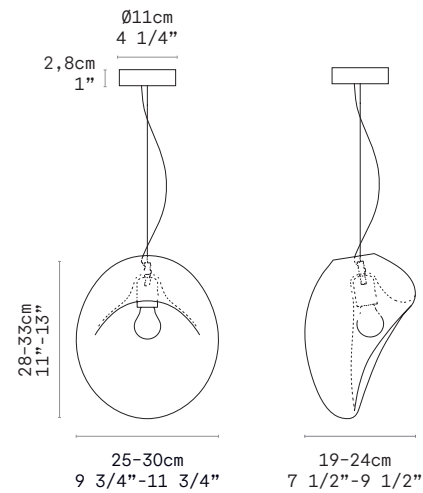

**LIGHTBODY S**

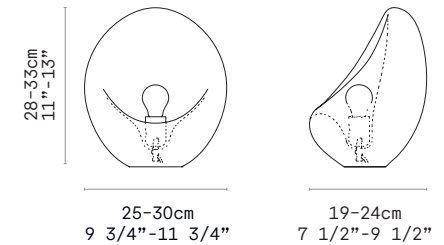

**LIGHTBODY T**

**Designer**

Jörg Hugo

**Category**

Indoor

**Marks**

Lightbody T: DRY LOCATION

Lightbody S: DRY LOCATION

**Typology**

Lightbody S:  
Pendant

Lightbody T:  
Table

**Dimming Protocol**

Lightbody T:  
on-off

**Materials**

Handblown glass / Metal

**Light source data**

E27 1 x 10W Retrofit LED  
(1 x max 43W Halogen Bulb)



# LIGHTBODY

S, T

Glass Diffuser

Glass Diffuser

Transparent

Shaded White

Transparent  
With Satin Finish

Shaded Burgundy

Transparent Pink

S  
(Pendant)



Model

T  
(Table)



## ETHER collection

Designed by Patrick Jouin, Ether is a cascade of borosilicate blown glass bubbles available in three different sizes (Ether S, Ether S 90 and Ether S 150). It can be customized on demand into any size, finish, and configuration. Also available with an optional remote controlled RGB LED. Ether is light and airy yet creates hypnotizing visual impact.





# ETHER

S, S 90, S 150

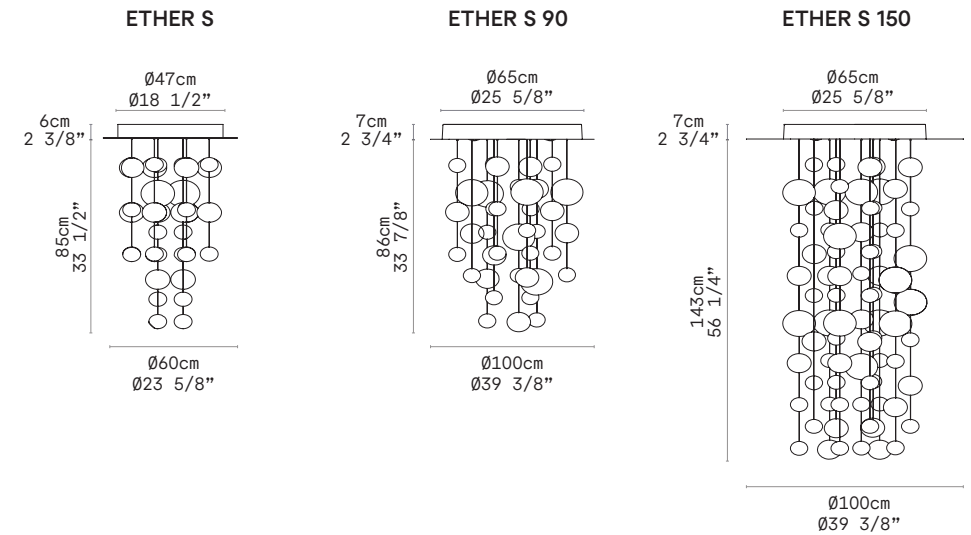

## Designer

Patrick Jouin

## Category

Indoor

## Marks

Ether S: DRY LOCATION



Ether S 90, Ether S 150: DRY LOCATION

## Typology

Pendant

## Materials

Blown borosilicate glass /  
Metal

## Light source data

Ether S:  
GU10

Ether S 90 and S 150:  
G53 or G53 + GU5,3 LED  
RGB

## BETA SMALL P-PL

Ceiling and wall lamp featuring layers of graduating sheets of glass.  
Structure in satin steel.



BETA SMALL P-PL





BETA SMALL P-PL

# BETA SMALL P-PL

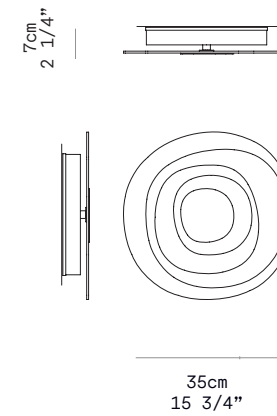

BETA SMALL P-PL

## Designer

Paolo Franzin

## Typology

Wall or Ceiling

## Dimming Protocol

Phase Cut

## Category

Indoor

## Light source data

LED 3000K

## Materials

Glass / Satin Steel

## Marks



## CUBI P-PL

Satin white handblown incamiciato ceiling and wall lamp. Structure in metal with arctic grey finish.



CUBI P-PL 11

BETA SMALL P-PL



BETA SMALL P-PL

# CUBI P-PL

11, 16

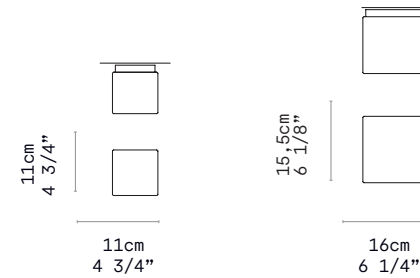

CUBI P-PL 11

CUBI P-PL 16

**Designer**  
LEUCOS Design Lab.

**Typology**  
Wall or Ceiling

**Dimming Protocol**  
Elv-Trailing Edge Phase Cut

**Category**  
Indoor

**Light source data**  
LED 3000K

**Materials**  
Blown and Layered Glass /  
Anodized Aluminum

**Marks**



## RECESSED

A collection of innovative recessed downlights, different materials expertly combine to offer a versatile solution for every need. Decorative recessed lights, thanks to Leucos's rich glass history, add genuine crystal details that take advantage of the elegant and dazzling effects of this ancient material.





# DISK



DISK

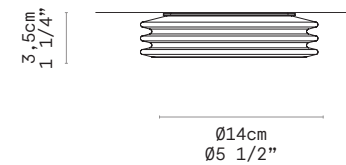

## Designer

Toso, Massari & Associates

## Category

Indoor

## Marks

Housing is UL Listed  
Rated for Damp Locations

## Typology

Recessed

## Light source data

LED 3500K  
LED 3000K  
LED 2700K

## Dimming Protocol

Dimmable electronic (ELV  
and 0-10 V)

## Materials

Glass/Metal

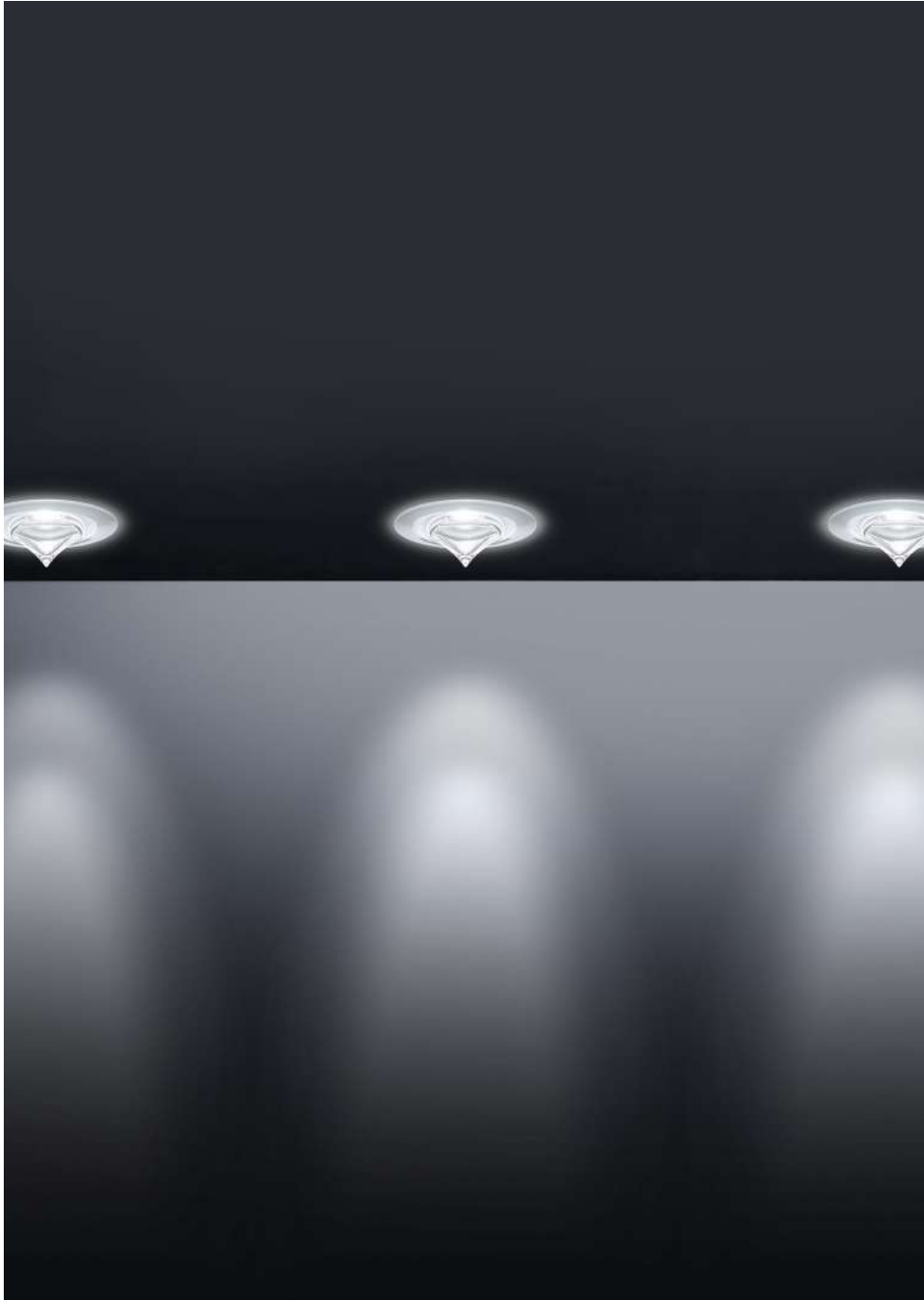

# DROP I



DROP I

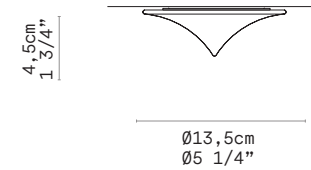

## Designer

Toso, Massari & Associates

## Category

Indoor

## Marks

Housing is UL Listed  
Rated for Damp Locations

## Typology

Recessed

## Light source data

LED 3500K  
LED 3000K  
LED 2700K

## Dimming Protocol

Dimmable electronic (ELV  
and 0-10 V)

## Materials

Glass/Metal



# ISIDE 2 I



ISIDE 2 I

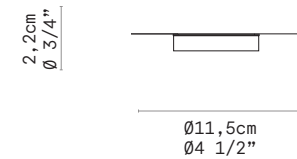

## Designer

Toso, Massari & Associates

## Category

Indoor

## Marks

Housing is UL Listed  
Rated for Damp Locations

## Typology

Recessed

## Light source data

LED 3500K  
LED 3000K  
LED 2700K

## Dimming Protocol

Dimmable electronic (ELV  
and 0-10 V)

## Materials

Glass/Metal

## JJ collection

The JJ Collection offers one of the most extensive ranges on the market, from table to floor and pendant versions, including JJ Small, JJ Mid, JJ Big, JJ Great, and the latest JJ Grip.

These large-scale, matte lacquered aluminum lamps are available in six outdoor-grade finishes with UV protection: White, Black, Amarant Red, Mica Blue, Sablé Grey, and Rust Brown, with a matching steel base.

The interior of the diffuser is finished in white lacquer, and custom colors are available upon request.

Both indoor and outdoor versions are available, equipped with dimmable, user-replaceable LED light sources. Lighting control options include a push-dim on the cord or wireless CASAMBI® Smart Lighting Control, combining classic design with modern technology for versatile spaces.



JJ BIG - FLOOR  
Color: Matte Mica blue





**JJ GREAT - PENDANT**  
Color: Matte White

# JJ GREAT

JJ GREAT - Floor, JJ GREAT - Pendant



**JJ GREAT - FLOOR**

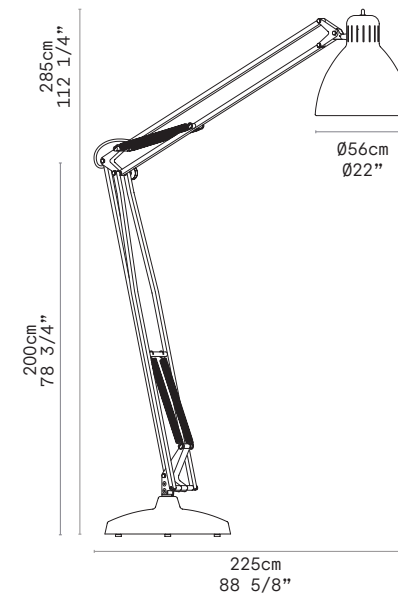

**JJ GREAT - PENDANT**

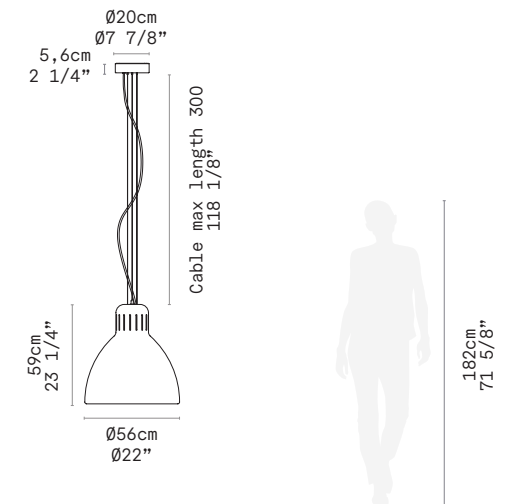

## Category

JJ GREAT-Floor:  
Indoor, Outdoor  
JJ GREAT-Pendant:  
Indoor

## Tipology

Floor or pendant

## Marks

Floor Indoor: DRY LOCATION  
Floor Outdoor: WET LOCATION  
Pendant Indoor: DRY LOCATION

## Light source data

LED 3000K  
LED 2700K

## Materials

JJ GREAT - Floor:  
Aluminum, Steel base

JJ GREAT - Pendant:  
Aluminum

## Dimming Protocol

JJ GREAT - Floor:  
Indoor: Dimmer on cord  
(push-dim) or Wireless  
CASAMBI® Smart Lighting  
Control  
Outdoor: Wireless CASAMBI  
Smart Lighting Control

JJ GREAT - Pendant:  
Push-dim; 0/1-10V; Dali





JJ BIG - GRIP

Color: Matte White

# JJ BIG

JJ BIG - Floor, JJ BIG - Grip

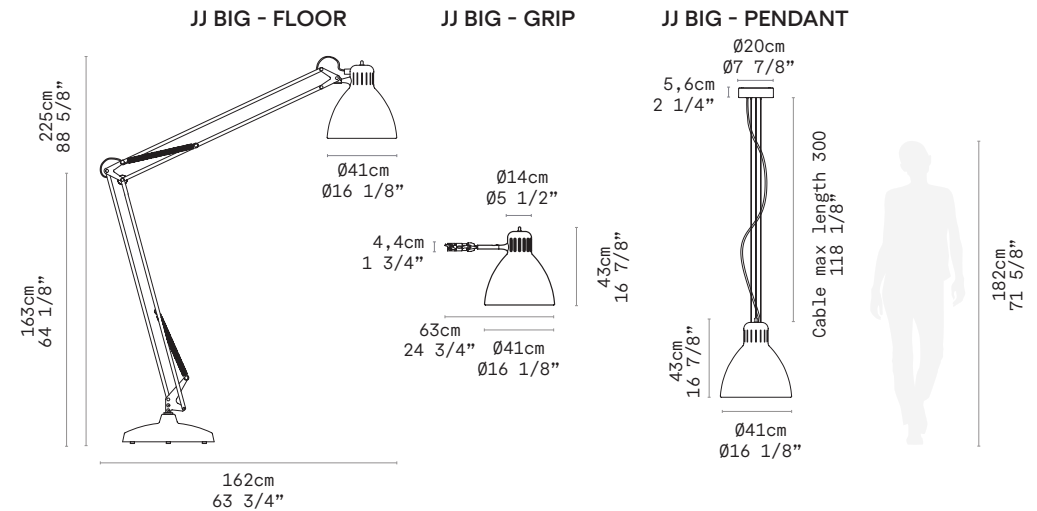

## Category

Indoor: JJ BIG-Floor, JJ BIG-Grip, JJ BIG-Pendant  
JJ BIG-Floor, JJ BIG-Grip:

Indoor and Outdoor

## Typology

Floor, grip or pendant

## Light source data

LED 3000K

LED 2700K

## Marks

Floor Indoor: DRY LOCATION

Floor Outdoor: WET LOCATION

Pendant Indoor: DRY LOCATION

## Materials

JJ BIG - Floor:

Aluminum, Steel base

JJ BIG - Grip, JJ BIG-Pendant:

Aluminum

## Dimming Protocol

JJ BIG - Pendant:

Push-dim; 0/1-10V; Dali

## JJ BIG - Floor:

Indoor: Dimmer on cord (push-dim) or Wireless CASAMBI® Smart Lighting Control

Outdoor: Wireless CASAMBI® Smart Lighting Control

## JJ BIG - Grip:

Indoor: Dimmer on cord (push-dim)

Outdoor: Wireless CASAMBI® Smart Lighting Control





JJ MID - WALL  
Color: Rust Brown

# JJ MID

JJ MID - Floor, JJ MID - Wall



JJ MID - FLOOR

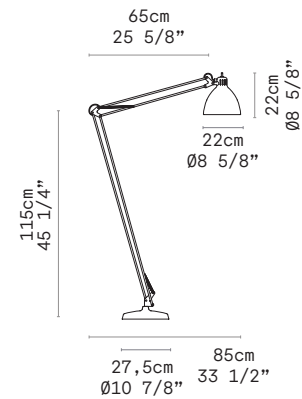

JJ MID - WALL

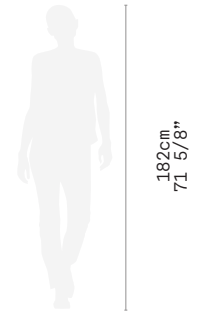
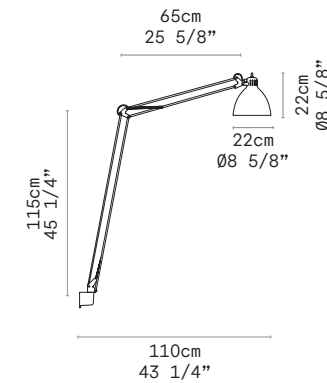

## Category

Indoor

## Light source data

LED 3000K  
LED 2700K

## Dimming Protocol

LED: touch dimmer  
(on diffuser)

## Tipology

Floor or wall

## Materials

Steel, aluminum diffuser

## Marks

DRY LOCATION

**JJ SMALL**

Color: Matte Mica Blue  
and Matte Black

# JJ SMALL

JJ SMALL - Table, JJ SMALL - Wall

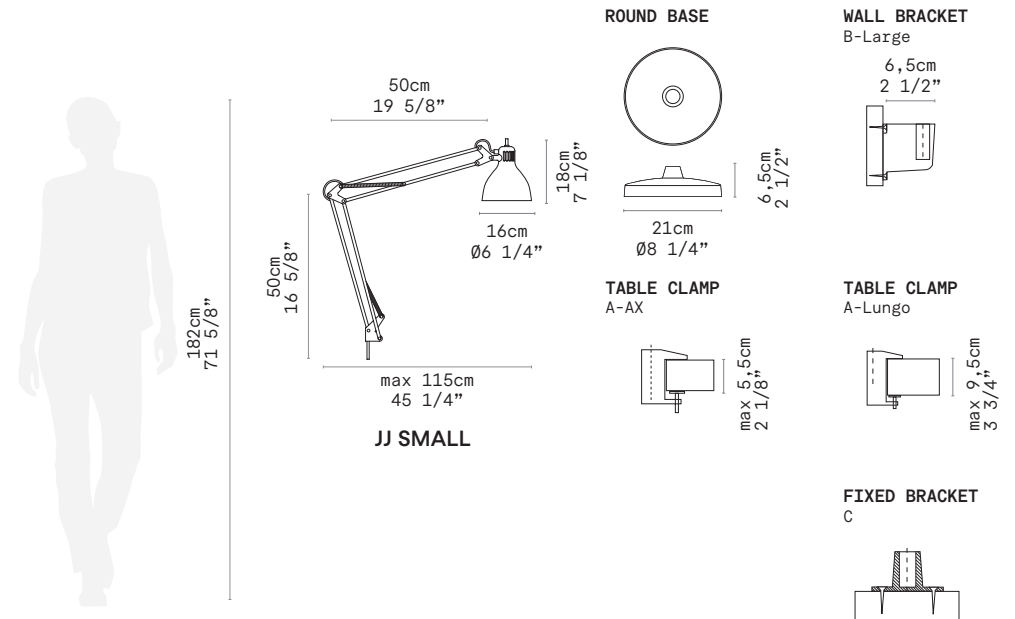
**Category**

Indoor

**Light source data**

LED 3000K

**Dimming Protocol**

LED: touch dimmer  
(on diffuser)

**Typology**

Table, wall

**Materials**

Steel, aluminum diffuser

**Marks**

DRY LOCATION

# JJ

- JJ GREAT
- JJ BIG
- JJ MID
- JJ SMALL

Diffuser

Diffuser

Matte Black



Matte Sablè Grey



Matte White



Matte Mica Blue



Rust Brown



Matte Amaranth Red



Structure

## Standard and bespoke projects

LEUCOS offers both standard products with a high degree of customization options and fully bespoke solutions.

The close association with ALU, a well-known display solutions provider for the retail design industry, enabled LEUCOS to acquire great new engineering and project management skills. These new strengths will be put to good service in the development of the LEUCOS product range of the future as well as a few selected custom projects.

**LA MAMOUNIA**  
MARRAKECH, MOROCCO

Products: Leucos Bespoke

Designer: Studio Jouin Manku

Lighting Designer: Voyons Voir -

Stéphane Carratero - Paris, France

Photo credits: La Mamounia,

Jouin Manku @ Alan Keohane



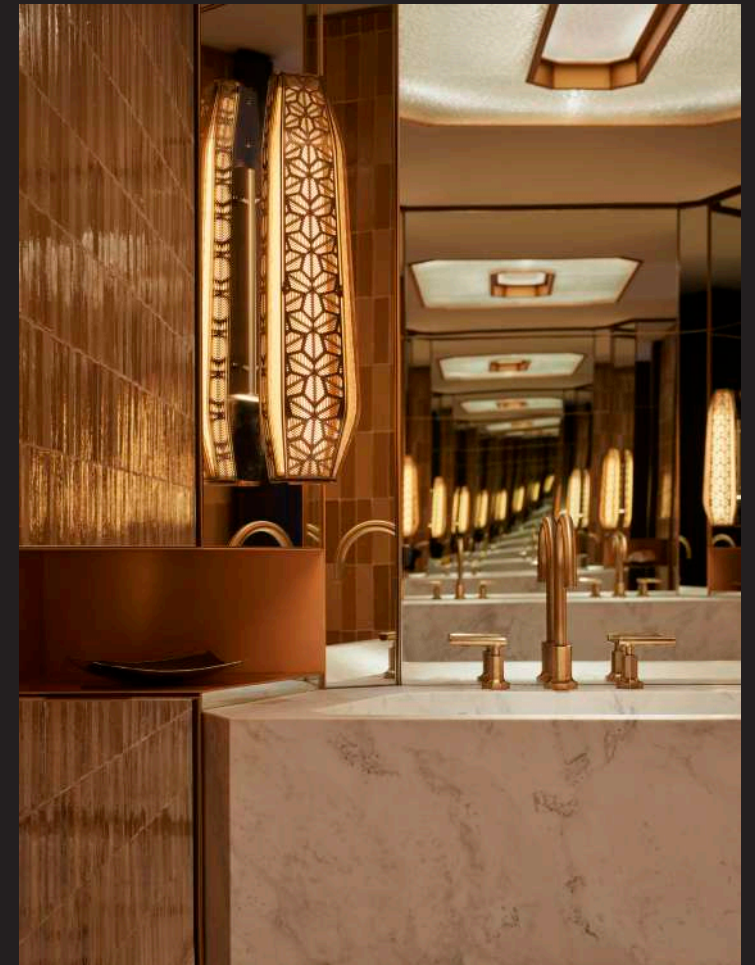
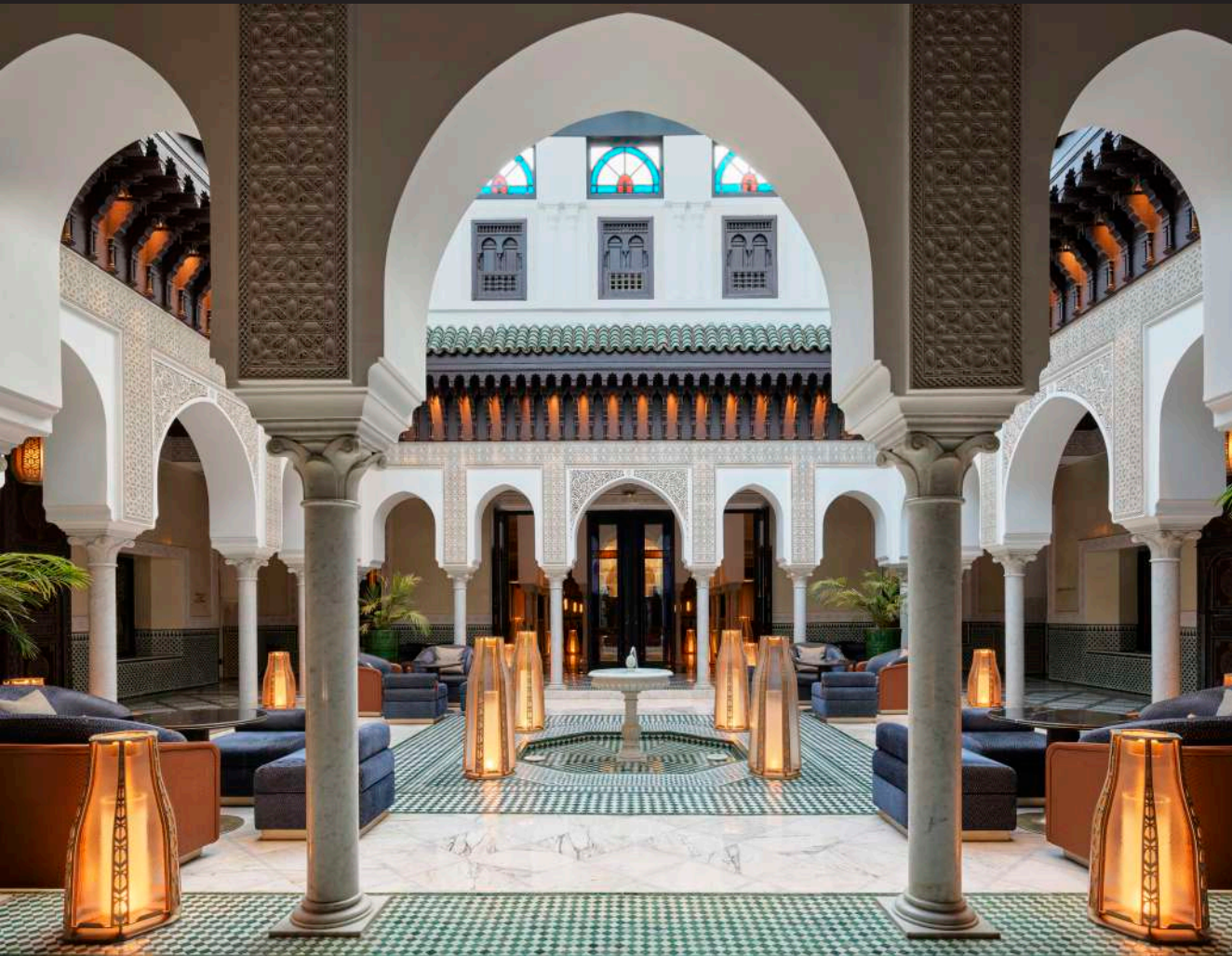







**LEVI RESTAURANT**  
COPENHAGEN, DENMARK

Product: Fully custom product

Architect: Johannes Torpe  
- Johannes Torpe Studios

Photo: courtesy to Johannes Torpe Studios  
/ Alastair Philipp







**LEUCOS SRL**

Via del Commercio, 22  
36060 Romano d'Ezzelino  
(Vicenza) Italy

[info.it@leucos.com](mailto:info.it@leucos.com)

**LEUCOS USA INC.**

6 Kilmer Rd Suite B  
Edison, NJ 08817  
[info.us@leucos.com](mailto:info.us@leucos.com)  
United States of America

**WH:** 2351 Us Highway 130 Ste B  
Dayton, NJ 08810-1648 United  
States of America  
[info.us@leucos.com](mailto:info.us@leucos.com)

[leucos.com](http://leucos.com)